

Touch^{nx}

Colour Touch Screen HMI

evolution of proven technology



Features

- Versatile & compact
- Microsoft Windows CE operating system
- Microphone, speaker & card reader interface as standard
- Optional integrated camera
- 4.3" Touchscreen LCD
- 24 bit RGB TFT 480 x 272 pixels
- Low power consumption
- Optional pre-installed Celeste^{ce} 128-tag HMI software package

Remsdaq's powerful, industrialised multi-function touch screen HMI. Suitable for many applications, across all market sectors

System

- 64MB SDRAM
- 512MB Flash
- 24Vdc (18-36Vdc) power supply
- Power consumption 3W typical
- 1 x 10/100 Base T(x) RJ mag jack
- 1 x Optional RS232 (RJ45) serial port
- 1 x CANBUS & 1 x I²C connection
- 1 x Card reader Interface
- 1 x Micro SD slot

Outputs to a Card Reader

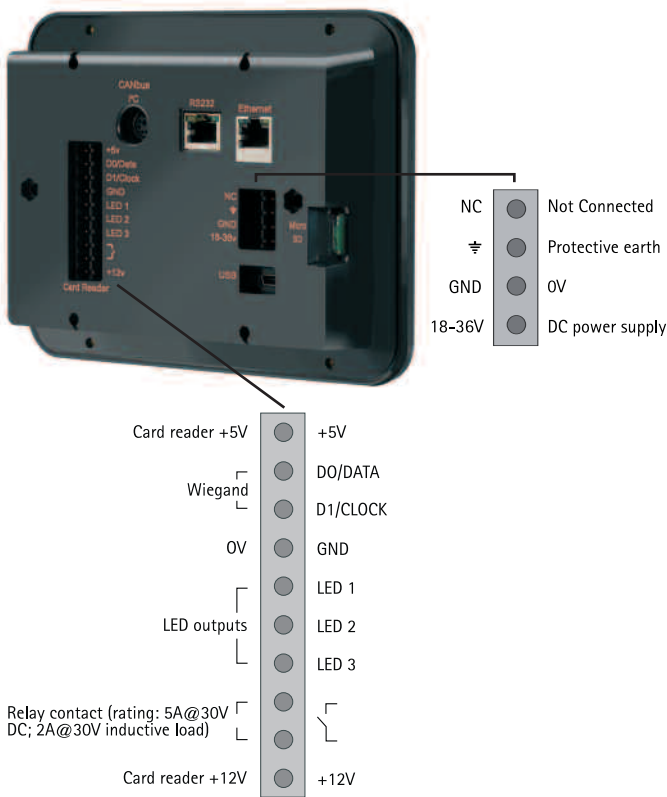

Training

Remsdaq offer a full suite of training services across all their products and services.

Please contact marketing@remsdag.com for more information.

Environmental

- Operating temperature -20 to +50° C
- Humidity up to 95% non-condensing @ 40° C

Mounting

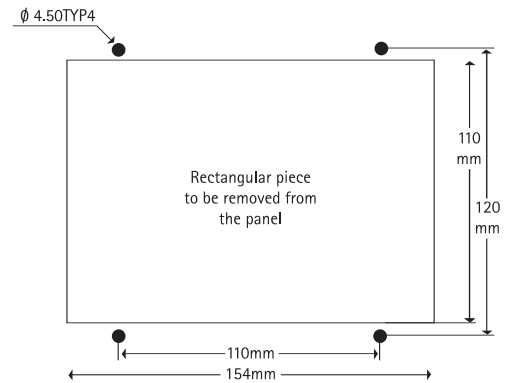

2-gang flush metal back box mounting

Ordering Information

Product Range	Product Code	Type	Opt1	Opt2	Opt3	Options
TX	TD	S	S	S	S	S = Standard no options fitted CAM = Camera fitted
						S = Standard no options fitted RS = RS 232 fitted
						S = Standard 24 Vdc
						S = Standard no option fitted SCA = Celeste ^{CE} 128-tag installed
						TD = Touch display
						TX = Touch ^{TX}



Remsdaq Limited, Parkway, Deeside Industrial Park, Deeside, Flintshire, CH5 2NL, United Kingdom.

tel: +44 (0) 1244 286495 fax: +44 (0) 1244 286496 web: www.remsdaq.com mail: sales@remsdag.com Registered in England No. 3417251.

Remsdaq has a policy of continuous product development and improvement. Whilst all information is correct at the time of going to press, we reserve the right to make changes without notice. All trademarks are duly acknowledged.